

**16X
4013N**

Nissan X-Trail Md.2017

EU-pedestrian protection bar 60 mm with cross pipe 42 mm
EU-Personenschutzbügel 60 mm mit integriertem Querrohr 42 mm
Protection avant, homologuée CEE, 60 mm, traverse 42 mm



*Compatible with Automatic Cruise Control /Forward Collision Mitigation
Kompatibel mit Abstandsregeltempomat /Auffahrvermeidungs-oder warnsystem
compatible avec radar de régulation de distance/ freinage autonome d'urgence

ASSEMBLY INSTRUCTION

Montageanleitung • Instructions de montage

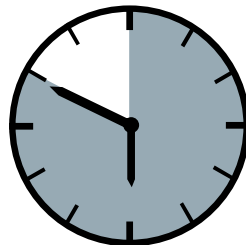

50 Minuten

Artikel-Nr:

16X4013N stainless steel
16X5013N black steel

Revision 1: 05.02.2020



M6:
10 Nm
M8 (a^o):
21,4 Nm
M8:
25 Nm

M6:
2 Nm



10
13

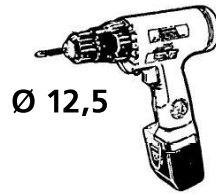
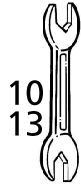

Ø 12,5

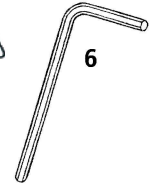

1

16X4013.1 / 16X5013.1

1x



Mounting kit: 16X9813

	M8 x 16; DIN 912 A2	2x
	M6 x 25; DIN 933 Zn	4x
	M8 x 25; DIN 933 A2	2x
	M6 x 25; DIN 7991 Zn	2x
	Ø3,5 x 13 DIN ähnl. 7981B A2	2x
	Ø 8,4; DIN 125 A2	2x
	Ø 6,4; DIN 9021 Zn	4x
	Ø 4,2 DIN 9021 A2	2x
	Getowell M6	2x
	SW 13	2x

2

16X5042_R / 16X5043_L

2x

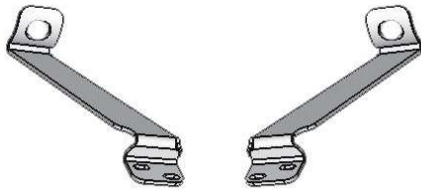

3

16X5065.1 R / 16X5065.2 L

2x

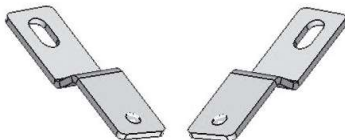

4

11F8043

2x



5

006009.1

4x



6

005498

2x



Ø9A2

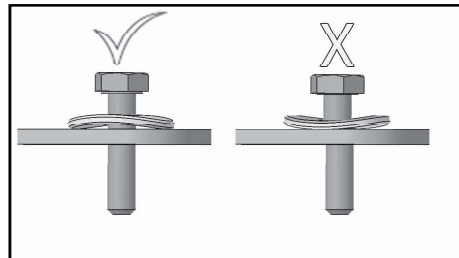

Step 1

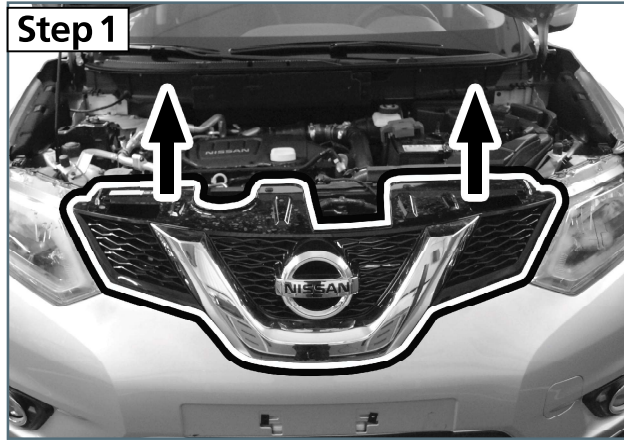

Step 2

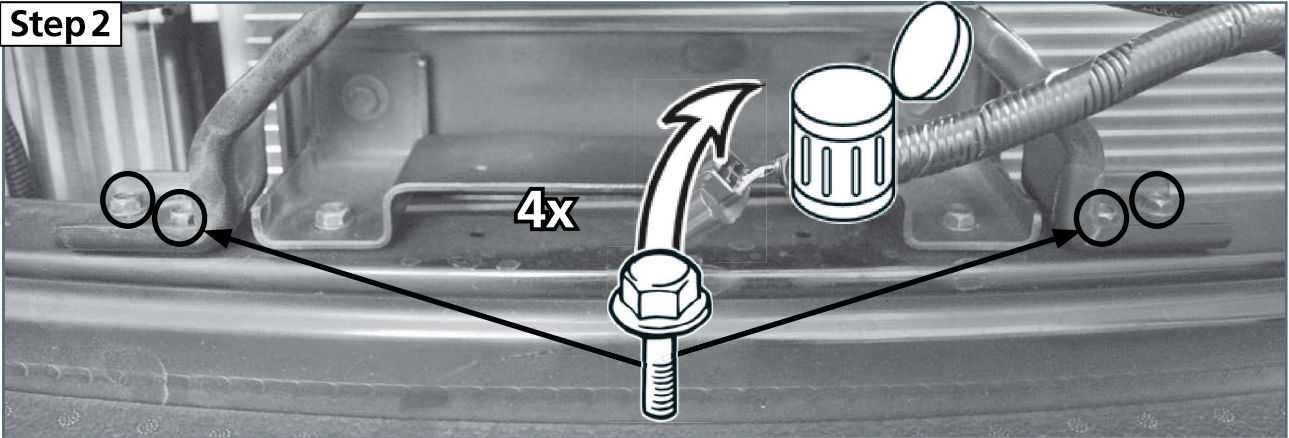

Step 3

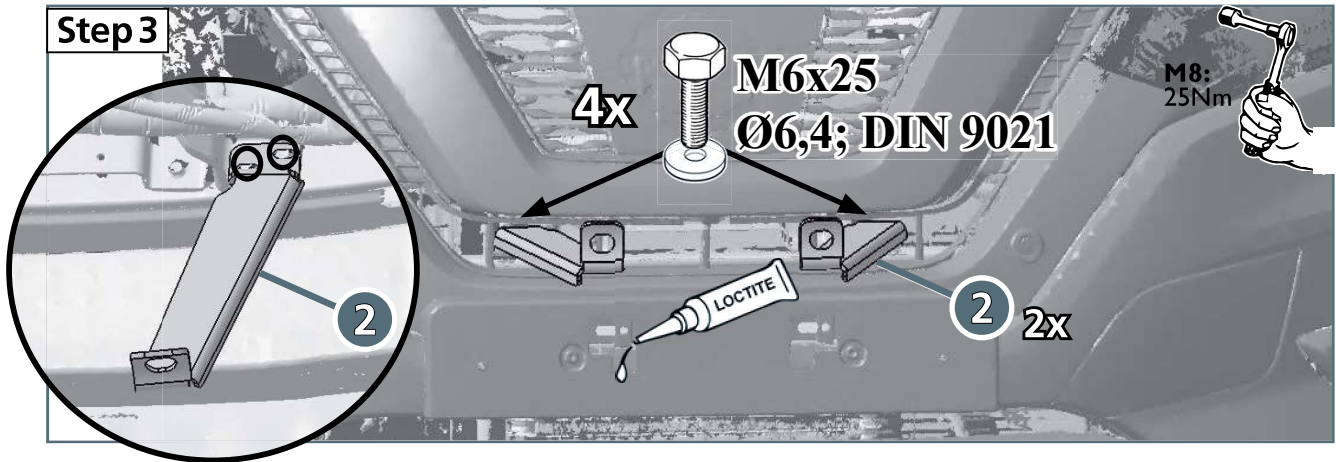

Step 4

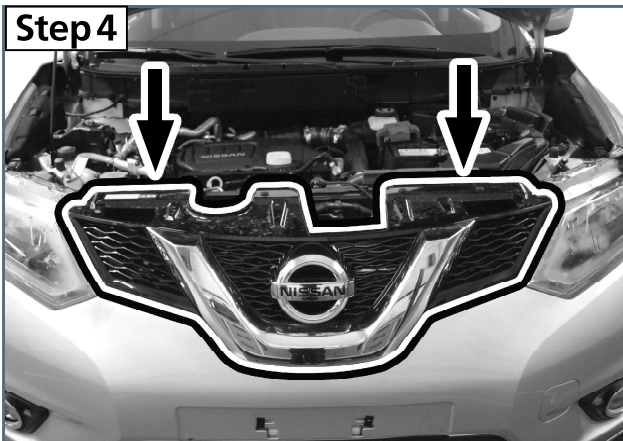

Step 5

