

10V
5790

Schublade 1180 / Montagesatz mit 10V9390
Drawer 1180 / Assembly-kit with 10V9390
Tiroir 1180 / Assemble-kit avec 10V9390



ASSEMBLY INSTRUCTION

Montageanleitung • Instructions de montage

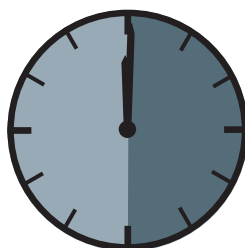

90 Minuten

Product-No.:
10V5790 Black Steel

Revision 10: 02.03.2017



www.antec-online.de

page/Seite 1

10V 5790

Schublade 1180 / Montagesatz mit 10V9390 Drawer 1180 / Assembly-kit with 10V9390 Tiroir 1180 / Assemble-kit avec 10V9390

Required tools / Benötigte Werkzeuge / Outillage requis

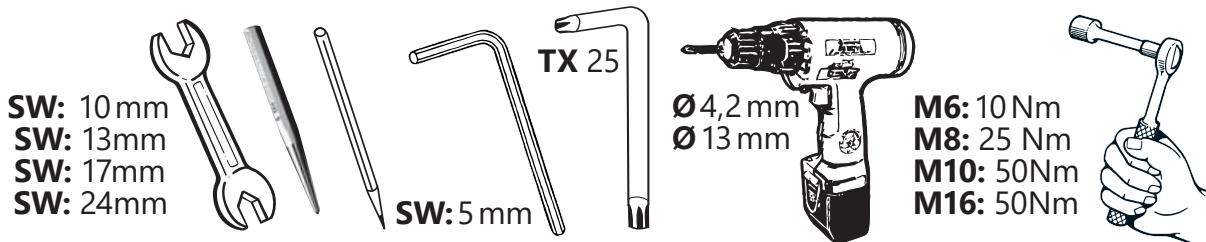

Parts list/Teileliste/Lista de accesorios

1 005580.3



2 005552

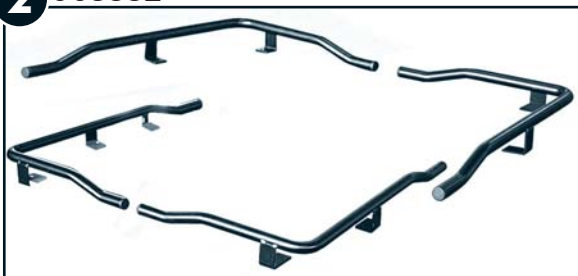

3 006066



a		ø5,5x25; DIN 7976	2x
b		ø5,5x25; Zebra piás	8x
c		M6x12; ~ISO7380 A2	6x
d		M6x25; ~ISO7380 A2	8x
e		M6x20; DIN 933	2x
f		M8x20; DIN 933	2x
g		M6 weld nut/Anschweißmutter/ soudure écrou	6x
h		ø8; DIN 127	2x
i		ø6,4; DIN 9021	6x
k		ø8,4; DIN 9021	2x
l		ø4,2	1x
m		M6; DIN 985 Zn	2x

Assembly-kit / Montagesatz / Assemble-kit

10V9390

5 M10; 10V5044 **4x** **6** ø11; 10V5133 **4x**

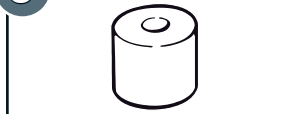

o		M10x60; DIN 933	4x
p		M10; DIN 934	4x
q		ø10; DIN 127	4x
r		ø10,5; DIN 9021	8x

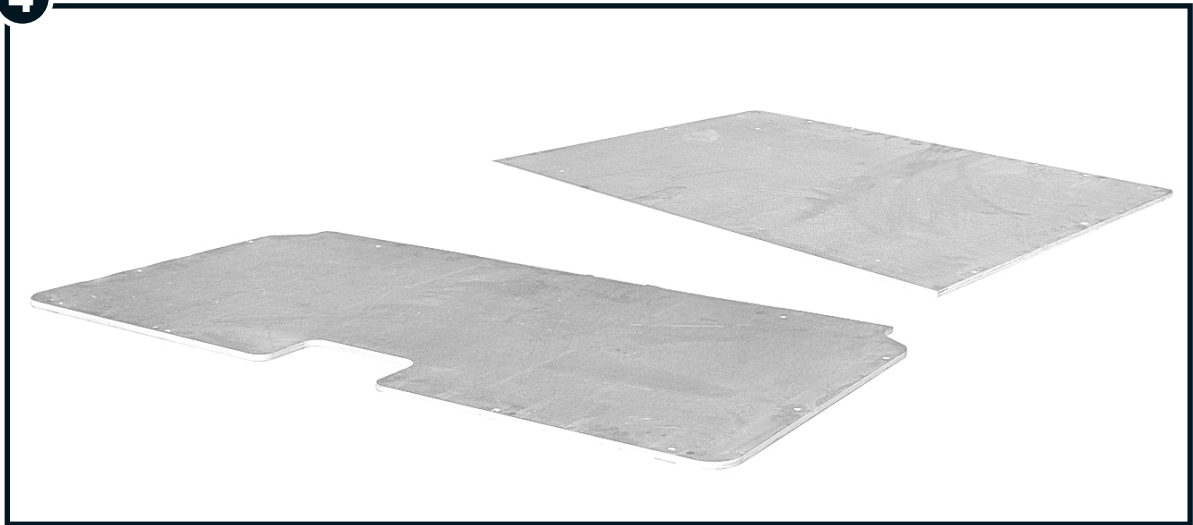

4

Artikel-Nr. Item-Nr. numéro d'article	KFZ Hersteller auto- motive manufacturer constructeur automobile	Bezeichnung designation désignation	Modell model modèle	Holzauflagen timber vehicle part exigences bois
10V5790	Mitsubishi	L200 DC	2009 ->	005562

Product-No.:
10V5790 Black Steel

Revision 10: 02.03.2017



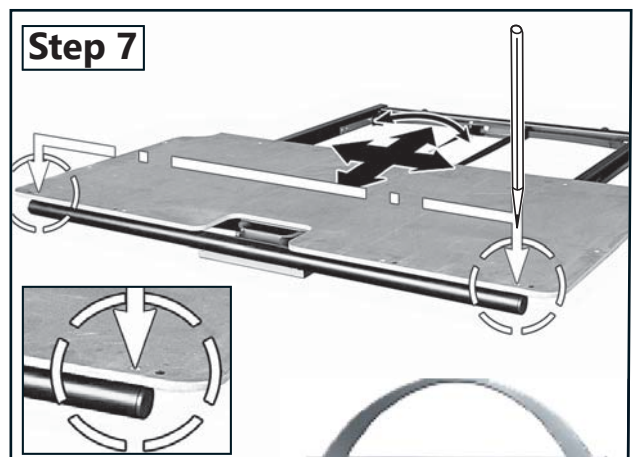
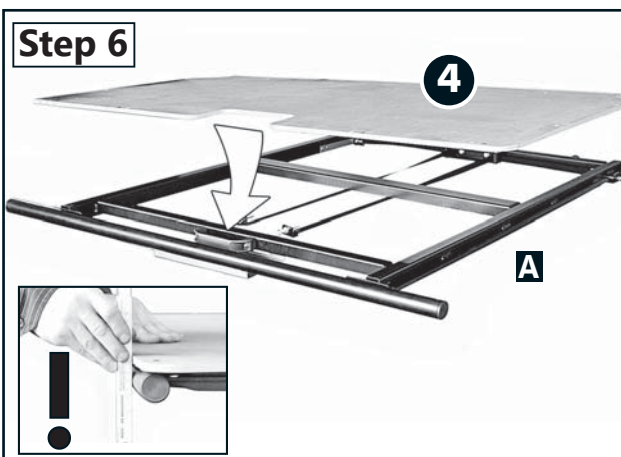
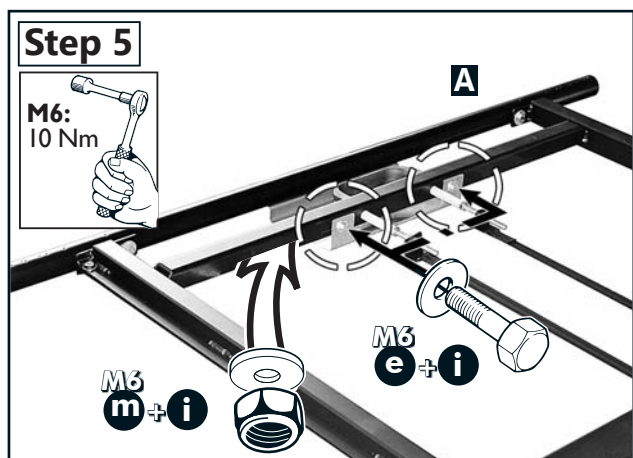
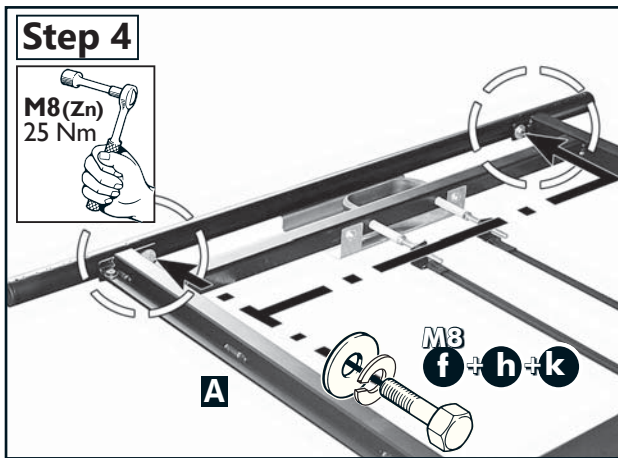
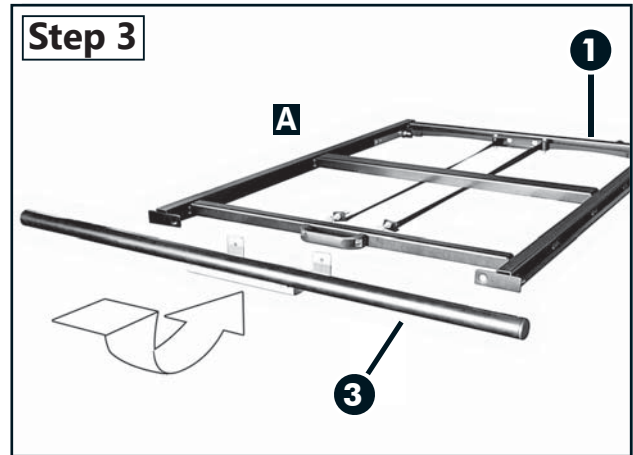
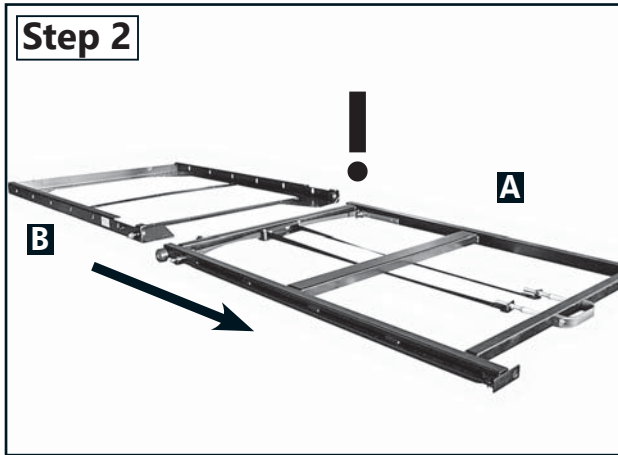
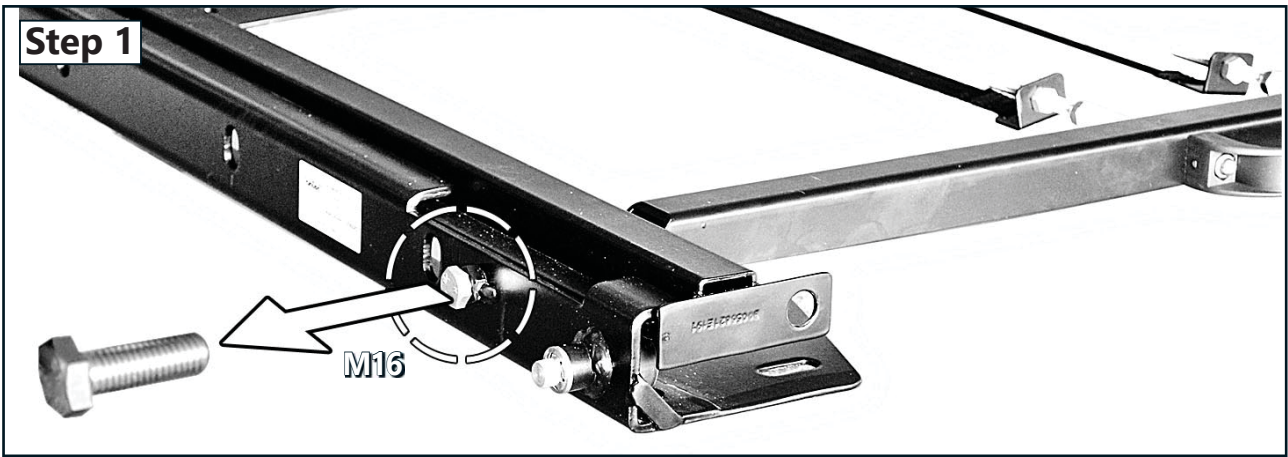

Product-No.:
10V5790 Black Steel

Revision 10: 02.03.2017



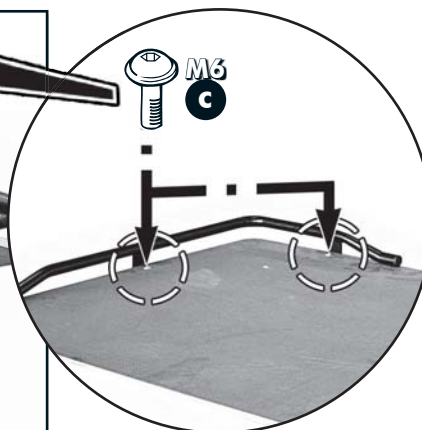
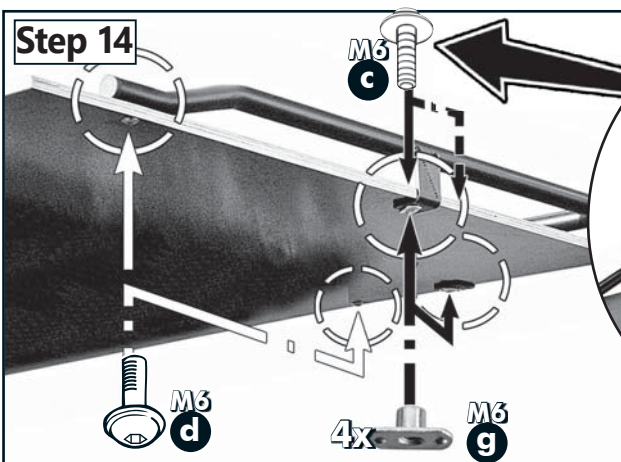
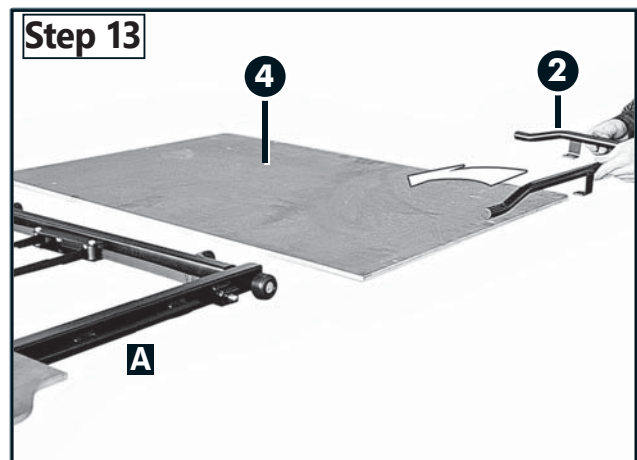
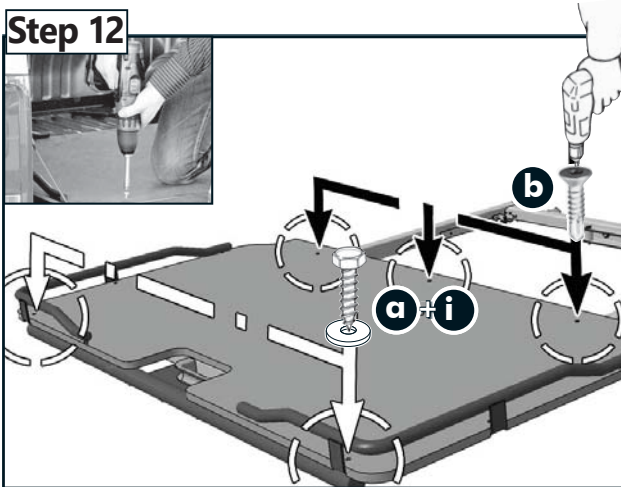
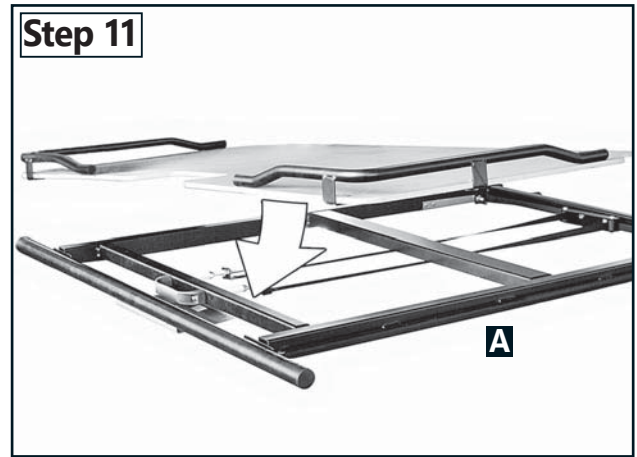
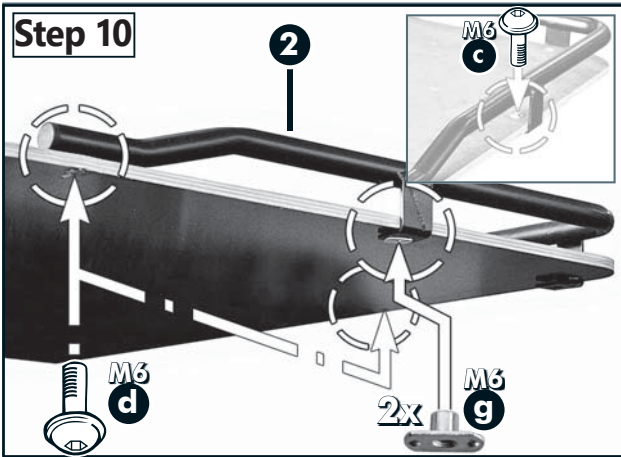
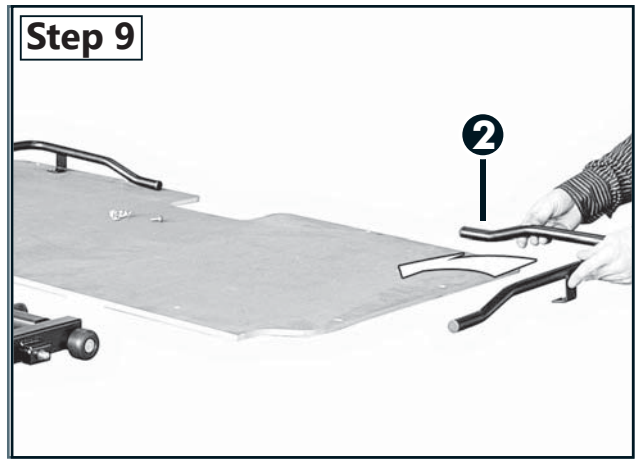
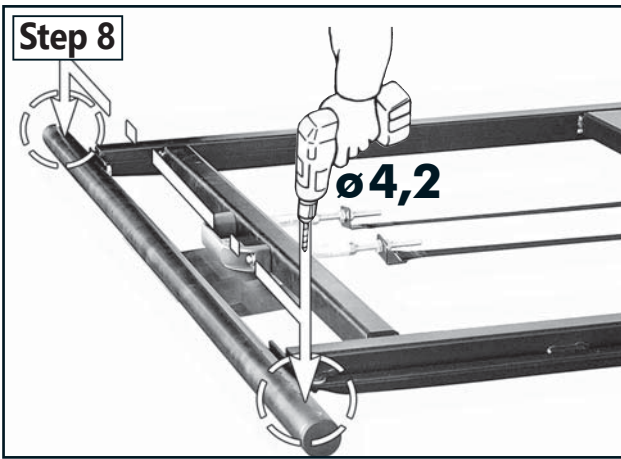

Product-No.:
10V5790 Black Steel

Revision 10: 02.03.2017



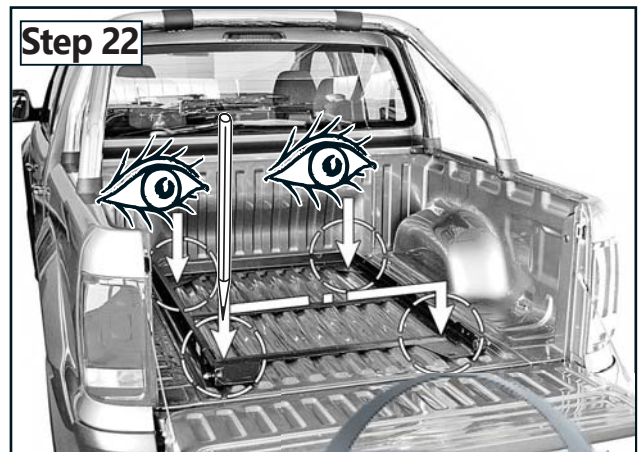
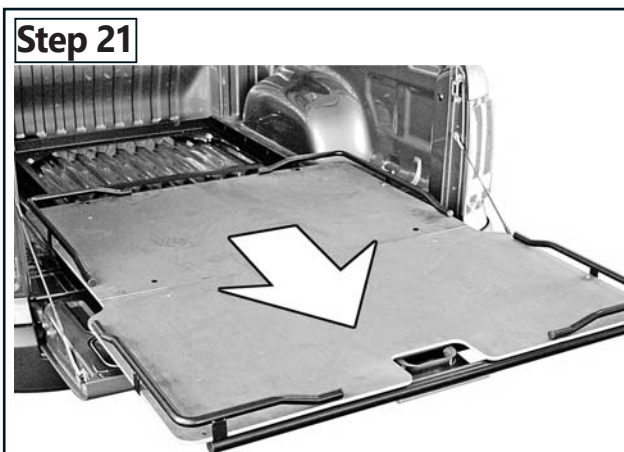
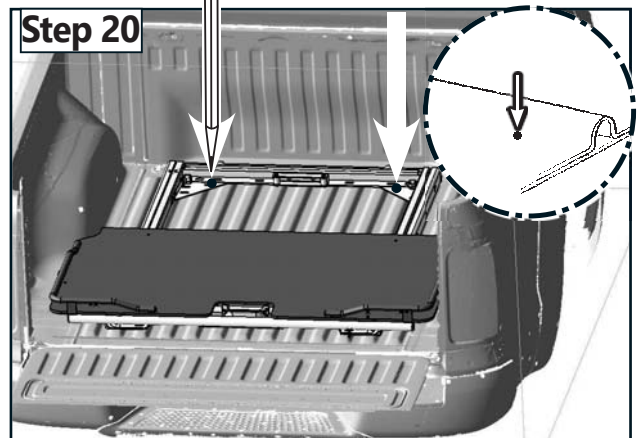
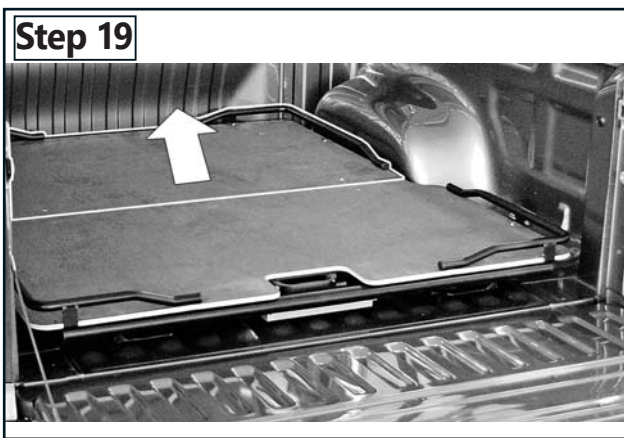
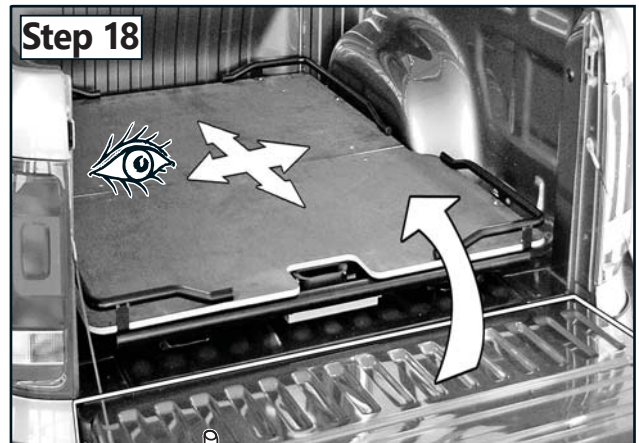
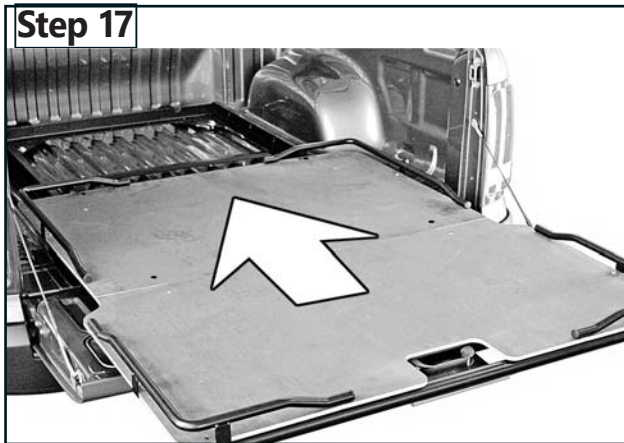
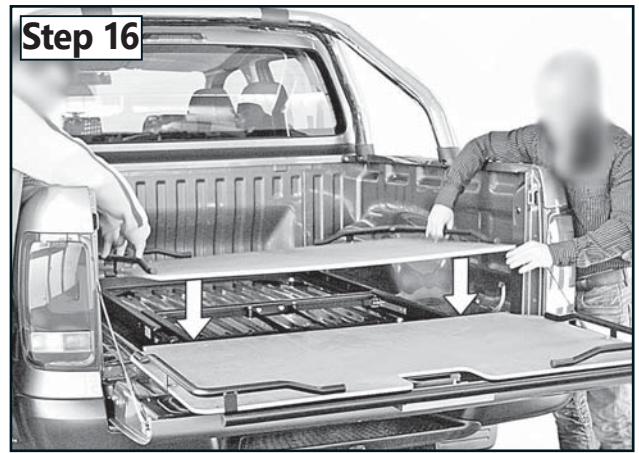
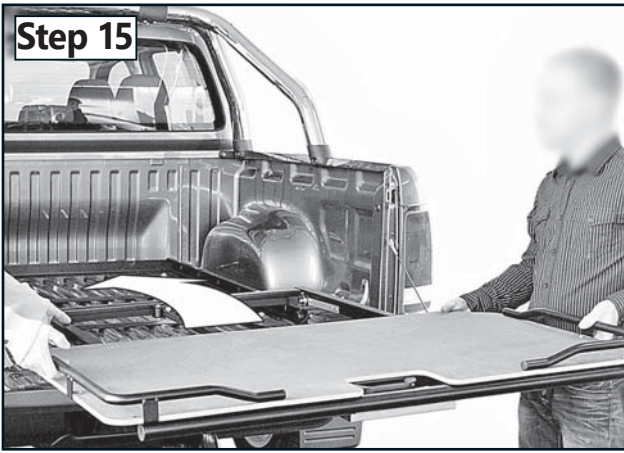

Product-No.:
10V5790 Black Steel

Revision 10: 02.03.2017



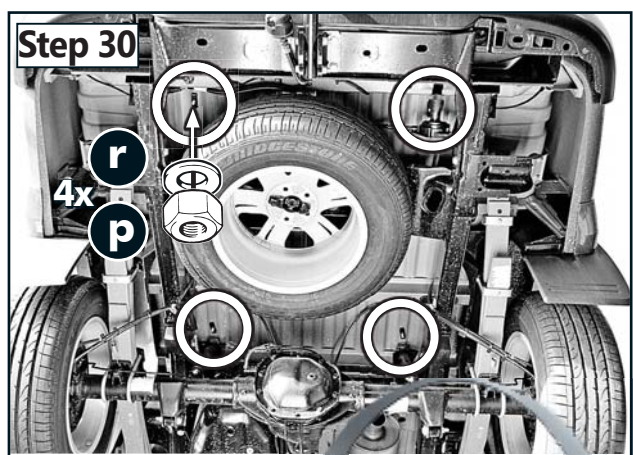
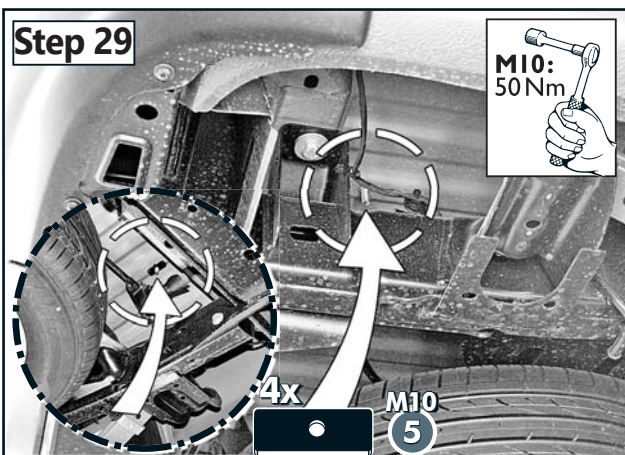
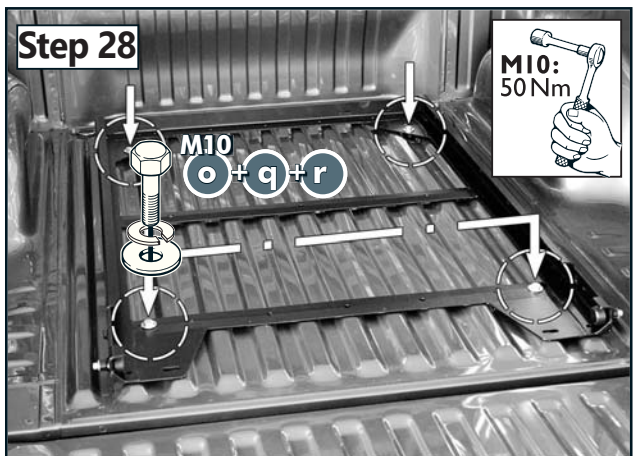
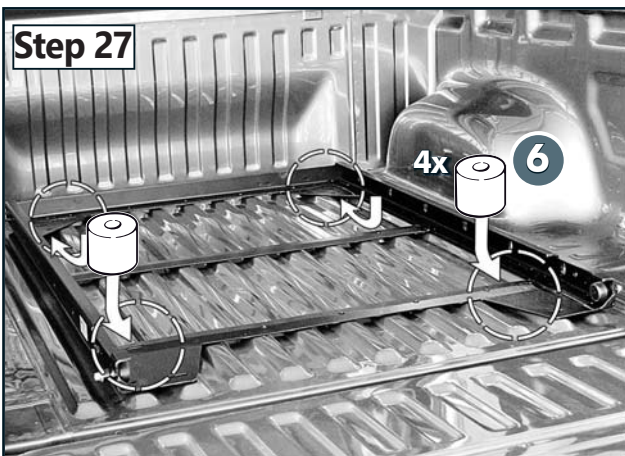
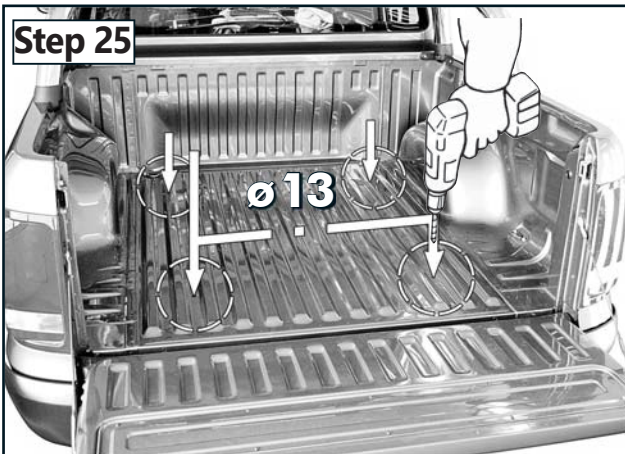
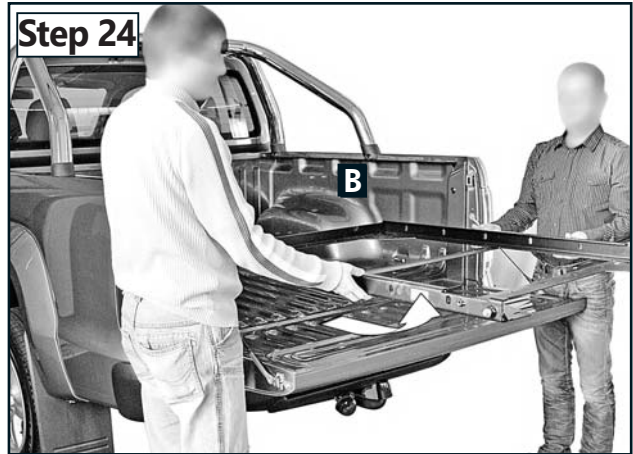

Product-No.:
10V5790 Black Steel

Revision 10: 02.03.2017



